

THE SUCCESSFUL STORY OF CONDENSING BOILERS

THE STRATEGY OF BOILERS MANUFACTURERS

Andrea Mariottini
Riello Gas Boilers Division

SOME TECHNICAL INFORMATION ABOUT CONDENSING BOILERS

The growth of domestic heating systems in Europe started in the fifties by selling boilers with oil burners for central heating.



In the seventies, selling of gas boilers for independent heating systems increased very quickly due to the customer's need to select the most appropriate level of comfort.

Unfortunately oil burner and gas boiler technologies were not able to get nor high efficiency or low emission levels.



The constant rise in the cost of gas forced the customers to buy more efficient boilers with lower emission levels.

New boilers with controlled air-gas ratio have been developed in order to substantially increase the efficiency performances.

The Dutch policy is the origin of the expansion of the condensing boilers in Europe.



In the ninties the Dutch Government started a program to boost the installation of the condensing boilers.

This policy led up to good improvements of the boilers efficiency but to poor results in terms of the whole heating systems efficiency.

Later on other European countries like Germany, UK, Denmark, France did follow the Dutch policy but they added new requirements in order to improve the efficiency of the whole system (boiler + heating system + building) reducing at the same time the environmental impact by cutting down the emission levels.

Starting from the second half of 2005 also the Italian Government has finally introduced new requirements that are increasing the installations of condensing boilers in the new buildings.

In the condensing technology the steam contained in the flues as consequence of the combustion of the mix air/gas, is made condense.

During the transition from the gas state to the liquid state, the steam transfers the latent heat recovered during the air/gas combustion process.

The total heat produced by the condensing generator is consequently given by the sum of the directly usable heat of the combustion process and the latent heat.

Then the latent heat of the steam and the heat of the combustion process are transferred to the water of the heating system.

Conventional Boiler

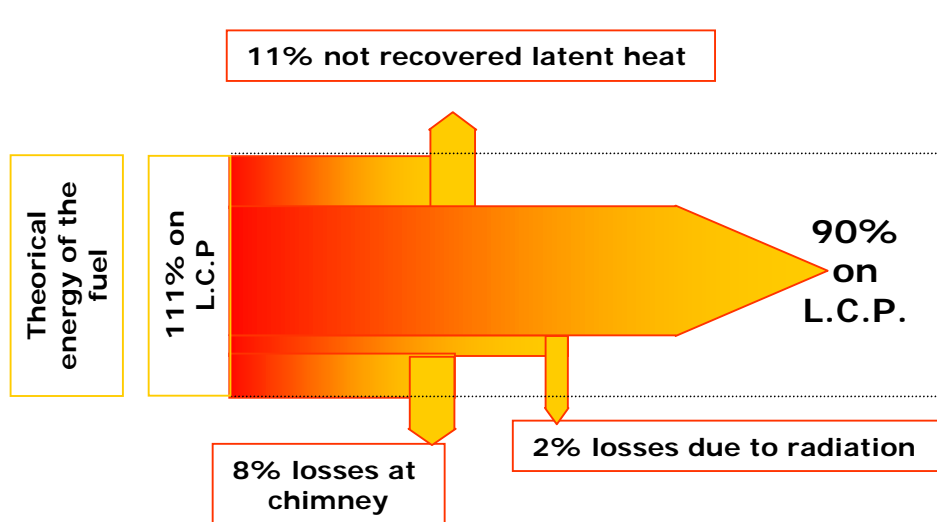

Condensing Boiler

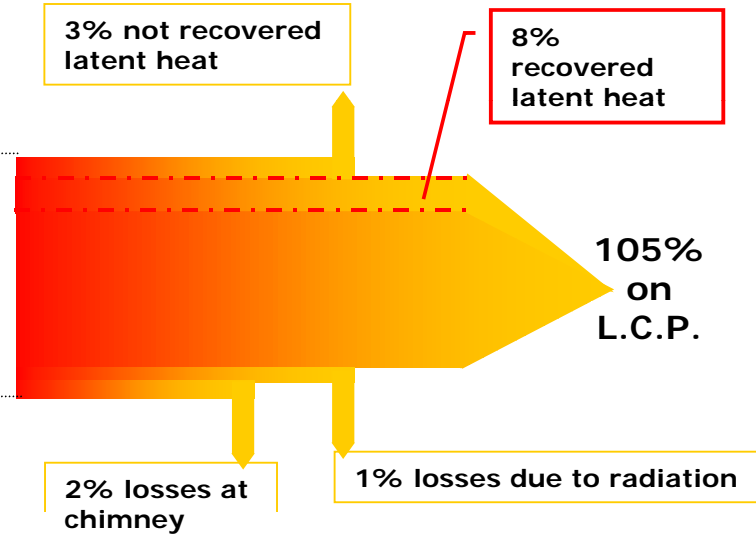

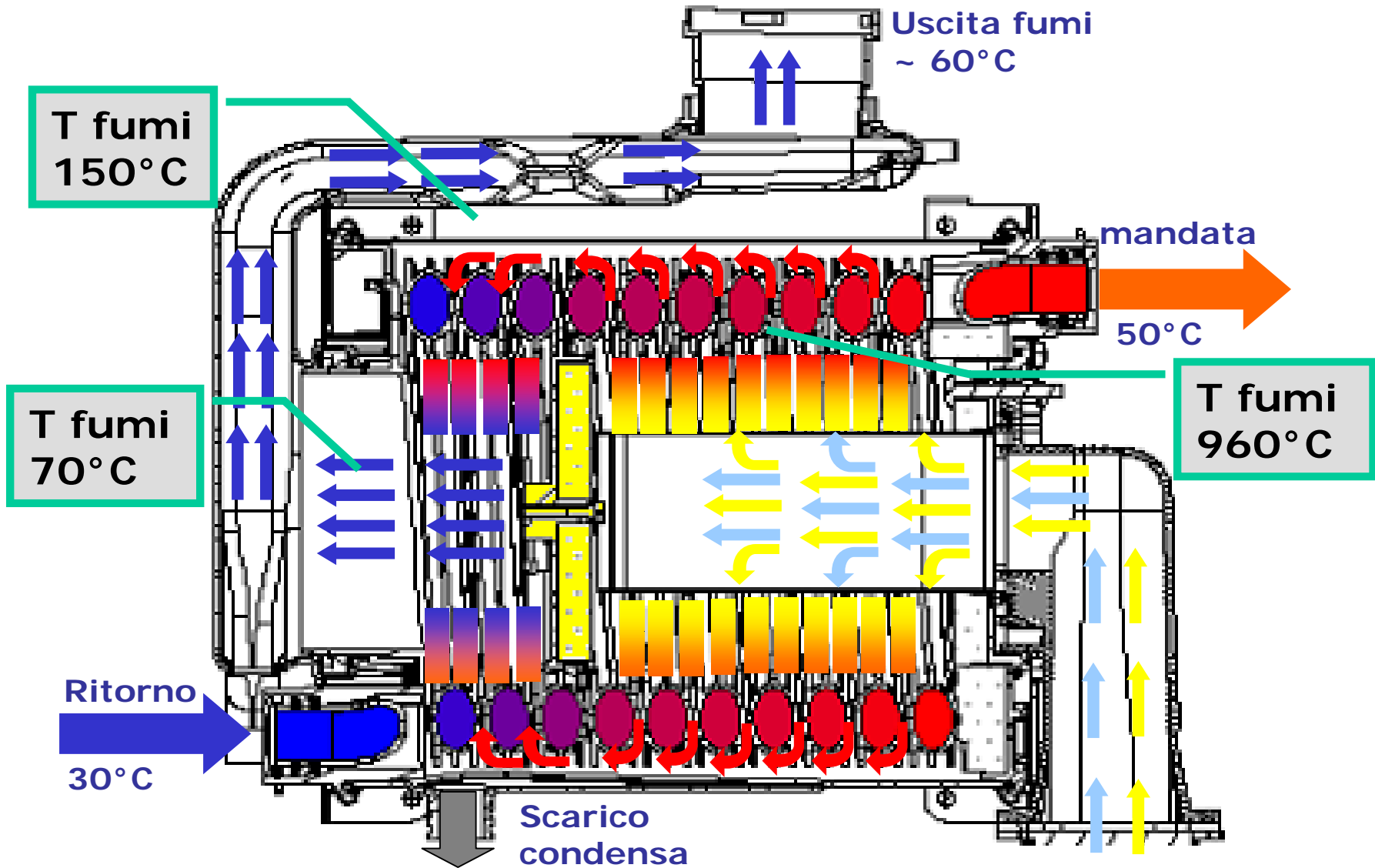

RENDIMENTI A REGIME DI FUNZIONAMENTO 80/60

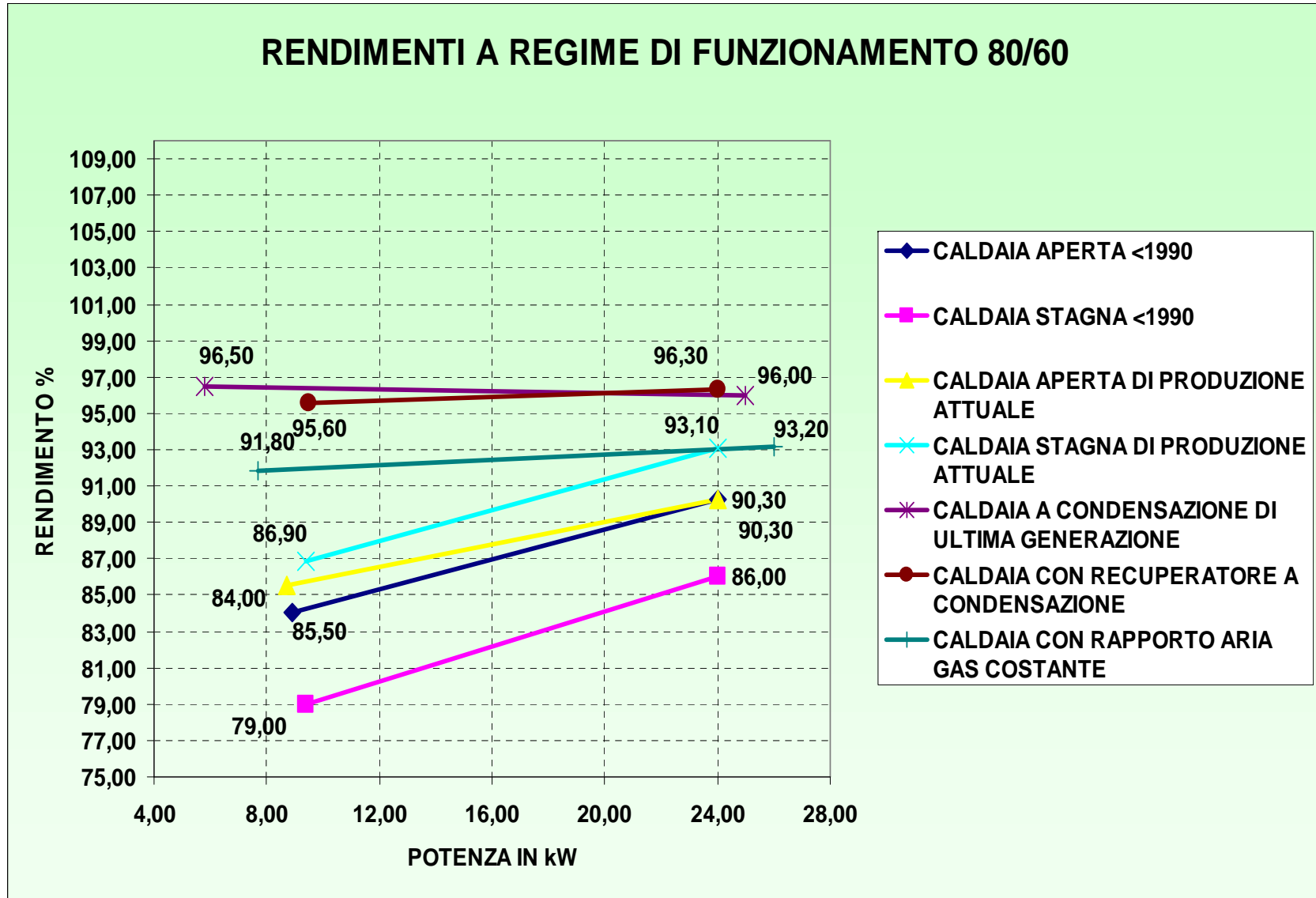

RENDIMENTI A REGIME DI FUNZIONAMENTO 60/40

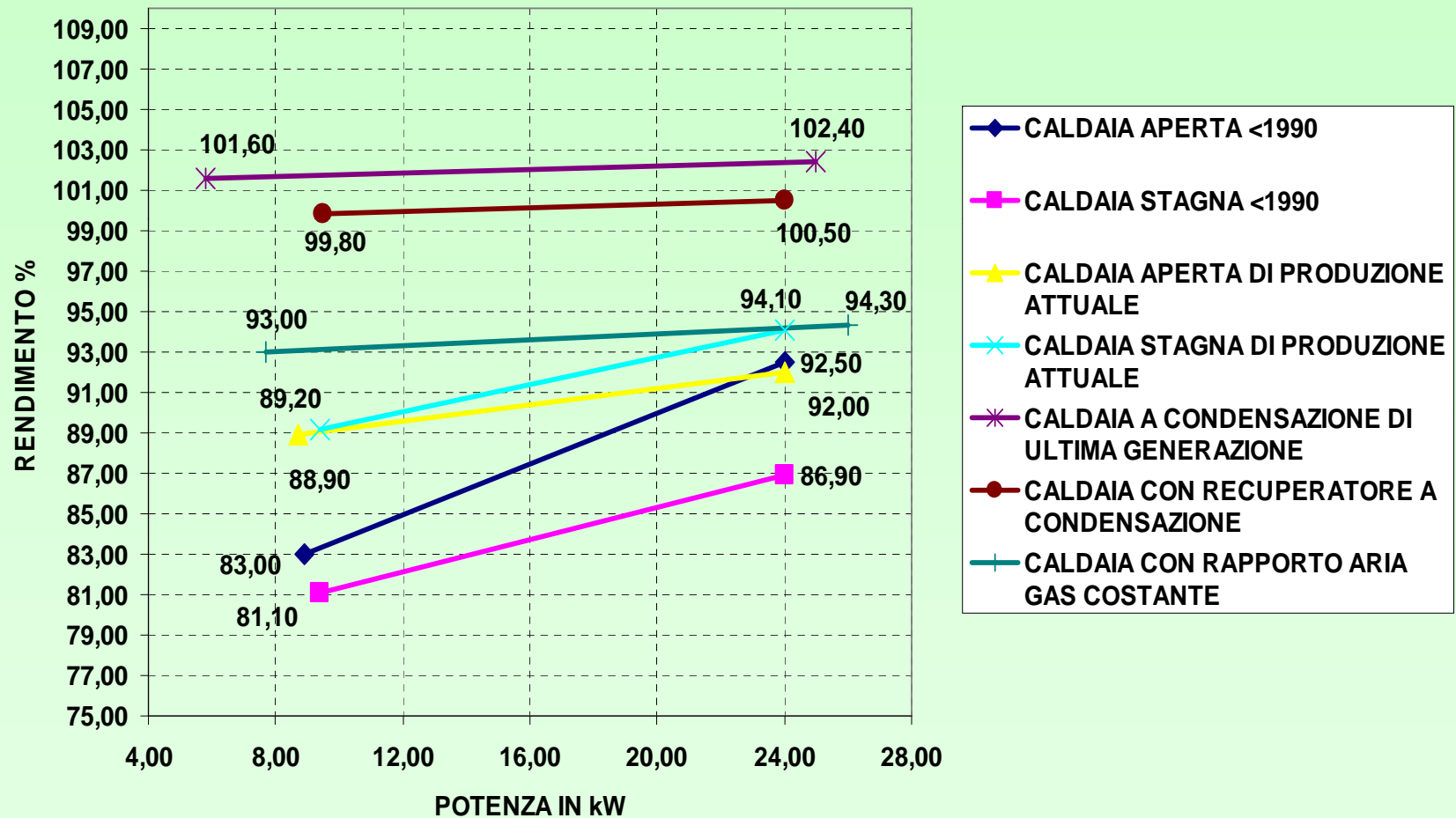

RENDIMENTI A REGIME DI FUNZIONAMENTO 50/30

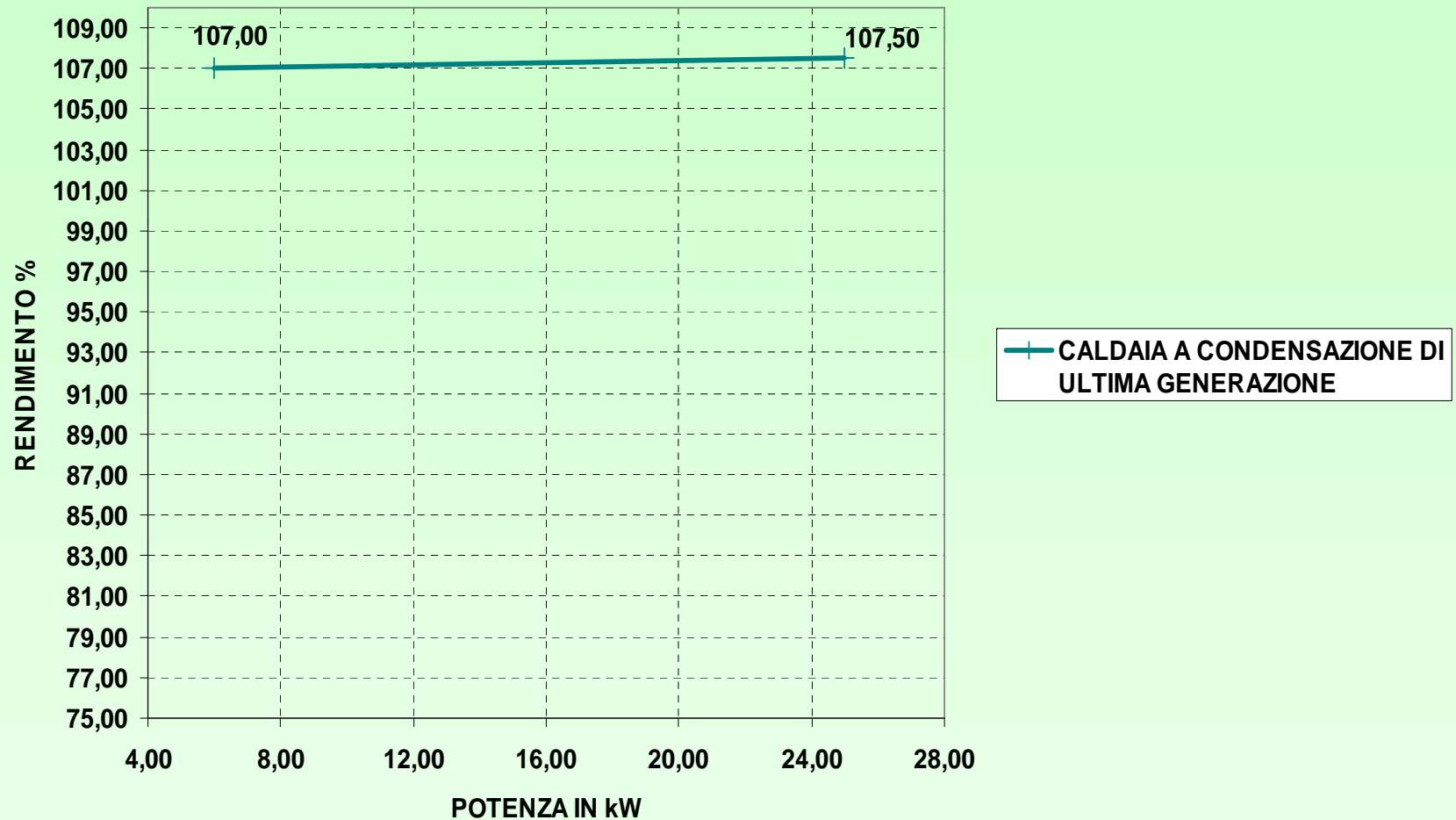

THE LEGISLATIVE REFERENCES

The Kyoto Protocol

At the real heart of the Kyoto Protocol is a set of legally-binding emissions targets for industrialized countries.

These emissions targets amount to a total cut of at least 5% from 1990 levels by 2008-2012.

The collective 5% reduction is shared out so that each involved country has its own individual emissions target.

However, all individual emissions targets must be achieved by the same commitment period of 2008-2012.

The Green Paper on Energy Efficiency

An energy strategy for Europe balancing sustainable development, competitiveness and security of supply.

By 2020 :

- up to 20% of EU energy use must be saved
- the share of energy production from renewable energy sources must reach at least 20% of the EU consumption
- the rise of global temperatures must be limited at the target of maximum 2° C

The Green Paper on Energy Efficiency

Gross energy consumption

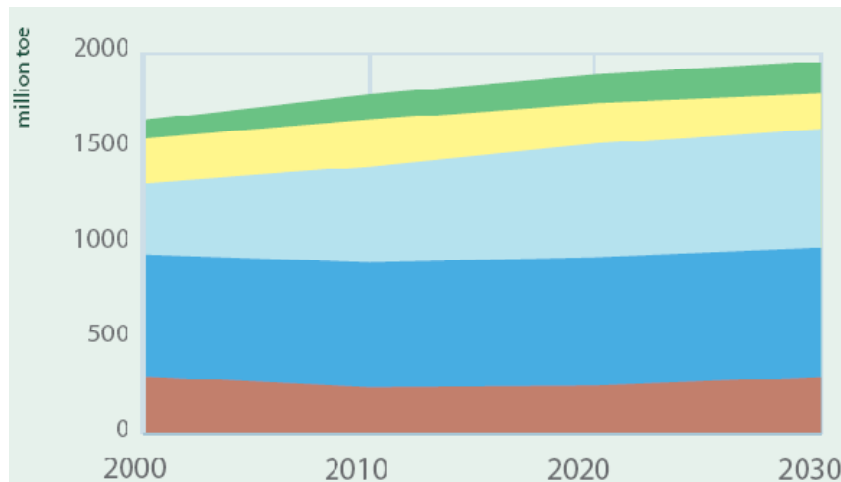

European energy resources

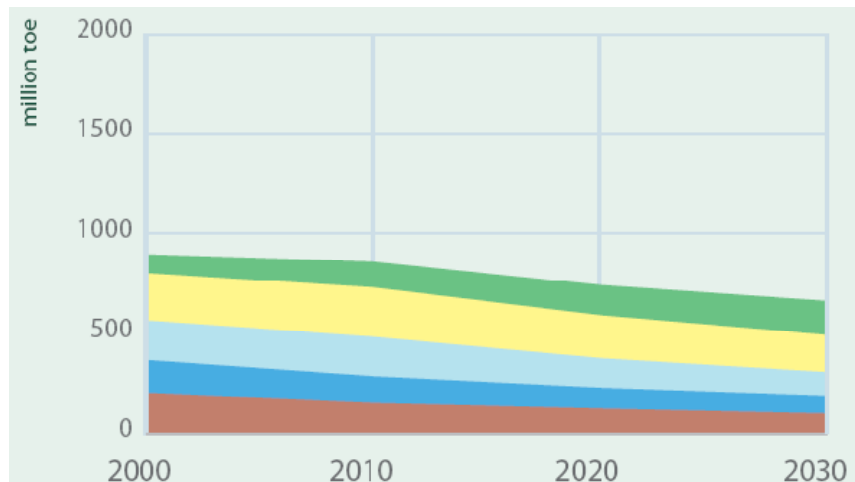

- EU consumption increases moderately but dependency is increasing from 50% to 70% as EU resources are almost finished
- Energy and climate changes are strategic issues (competitiveness and security of supply) and it is mandatory to cut global energy consumption and to increase the share of EU internal production

The Green Paper on Energy Efficiency

EU energy import dependency is rising; on current trends, gas imports would increase to 80% and oil imports to 90% within 2030.

As consequence of the increasing global demand for fossil fuels, oil and gas prices are rising; they have nearly doubled in the EU over the past two years.

Today, half of the EU gas consumption comes from only 3 countries; it is necessary to have new and different sources of gas supplies.

The Mandate M400

New and different sources of gas supplies mean different gas qualities.

The purpose of the mandate M400 is to ask to CEN to draw up standards for gas quality parameters for H-gas, that are the broadest possible within reasonable costs to create a competitive European gas market.

The new standards shall be adopted within five years of the acceptance of the mandate.

The Heating Energy demand in EU

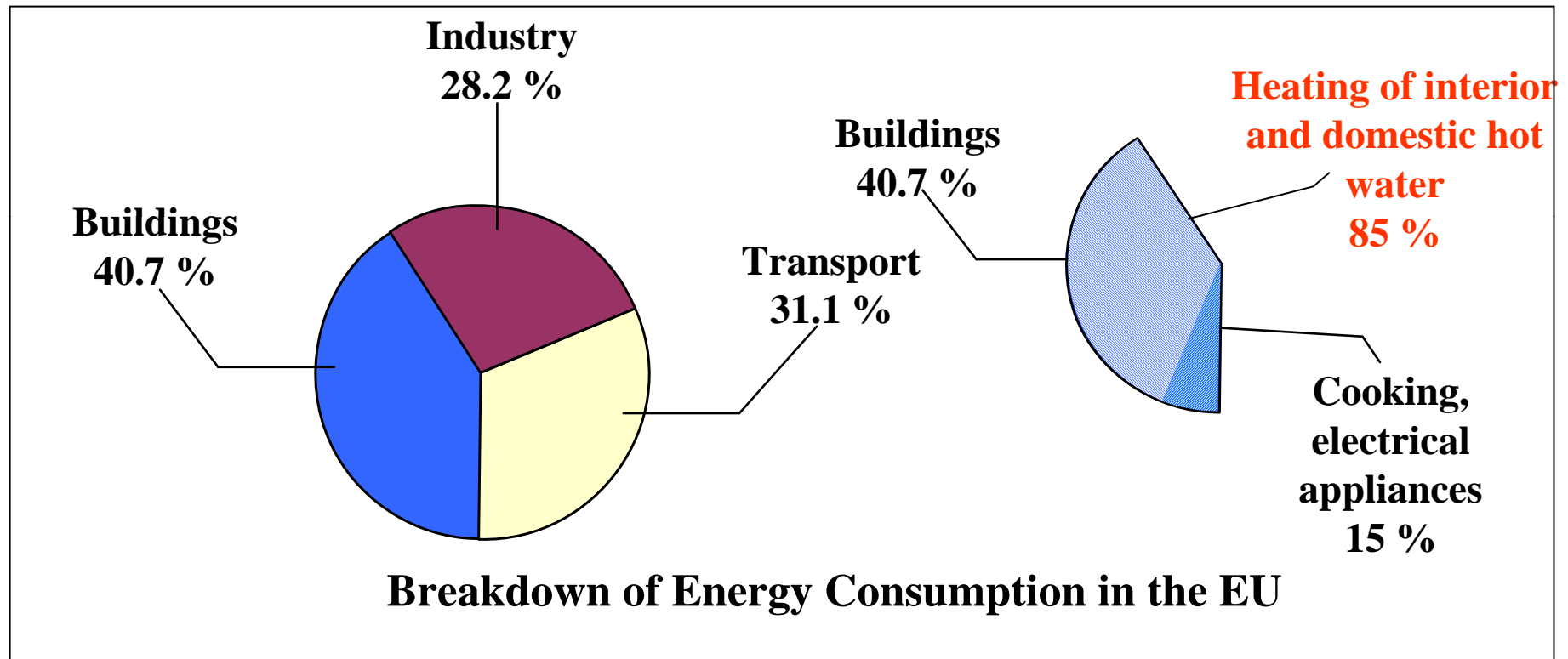

- The energy demand for heating and hot water of buildings is the biggest sector in the EU

European Directive 2002/91/CEE on Energy Performances of Buildings

The directive 2002/91/CEE is related to the energy performances of buildings and includes four main points:

- a common methodology of calculation of the integrated energy performance of buildings
- the application of minimum requirements on the energy performance of new and renovation buildings
- a system of certification for new and renovation buildings
- the inspection of boilers and of air-conditioning systems in buildings and, in addition, an assessment of the heating installation

European Directive 2005/32/CEE

- Directive 2005/32/CEE defines the guidelines for the eco-design of Energy Using Products (EUP)
- It is necessary to evaluate the environmental impact in any phase of their life
- Directive 2005/32/CEE is a framework directive; it is then necessary to develop specific implementing directives for several different groups of products

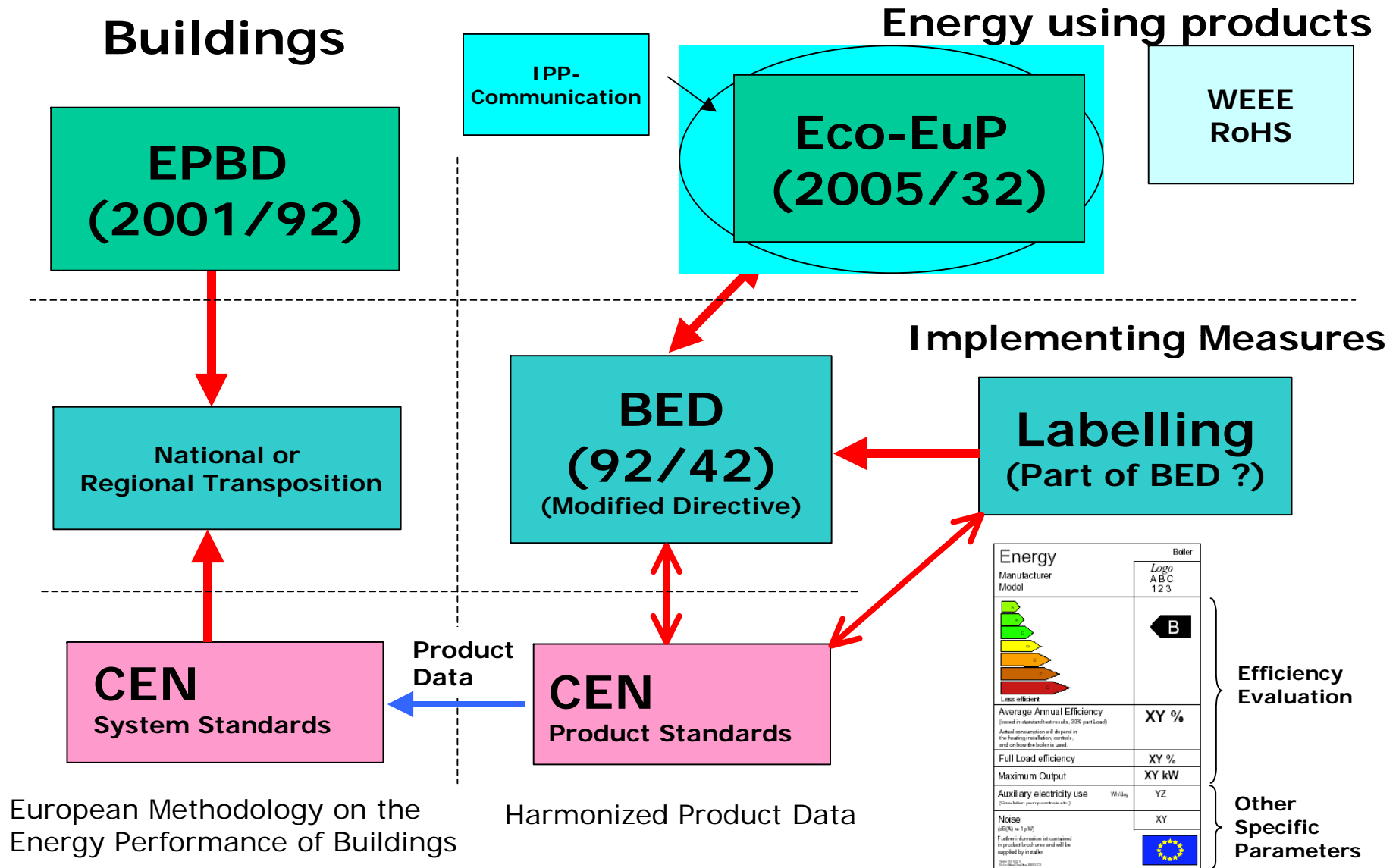

THE MANUFACTURER'S CONTRIBUTION

From 20 years boilers technologies and efficiencies are getting better ; they have to be integrated with other components to create an efficient heating system.



$\eta_p =$ Generator efficiency

$\eta_c =$ Controller efficiency

$\eta_e =$ Emitter efficiency

$\eta_d =$ Distributor efficiency

- For an optimum global efficiency and the customer satisfaction (comfort and pay back time), each boilers technology has to be matched with a specific type of controller, distributor and emitter
- The seasonal overall efficiency $\eta_p = \eta_p \times \eta_c \times \eta_e \times \eta_d$
- The EU energy consumption decreases if the seasonal efficiency of the heating system does increase

Manufacturers can provide not only single products but whole heating and domestic hot water production systems integrated with renewable energies for both independent ...

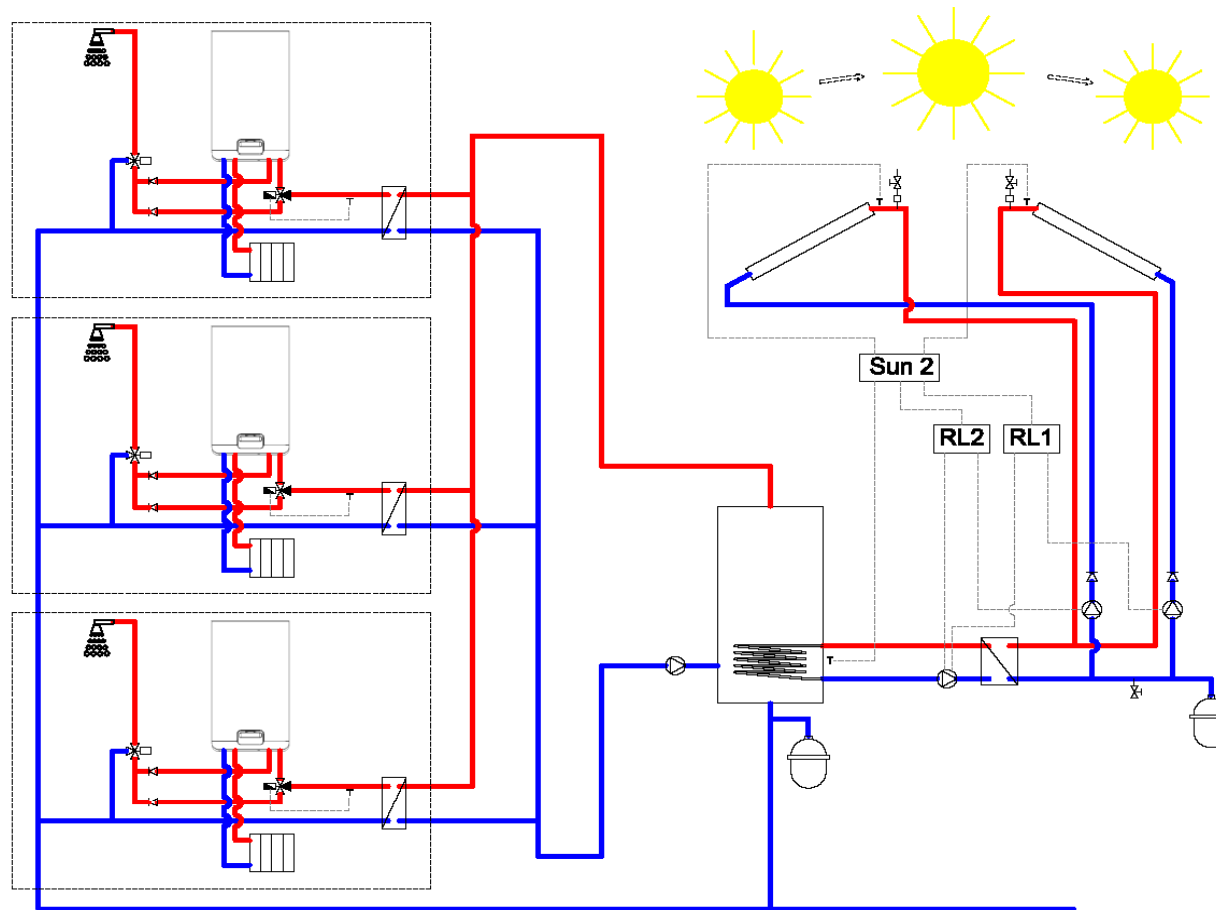

... or central heating systems in order to get the best results in terms of efficiency and energy consumption.

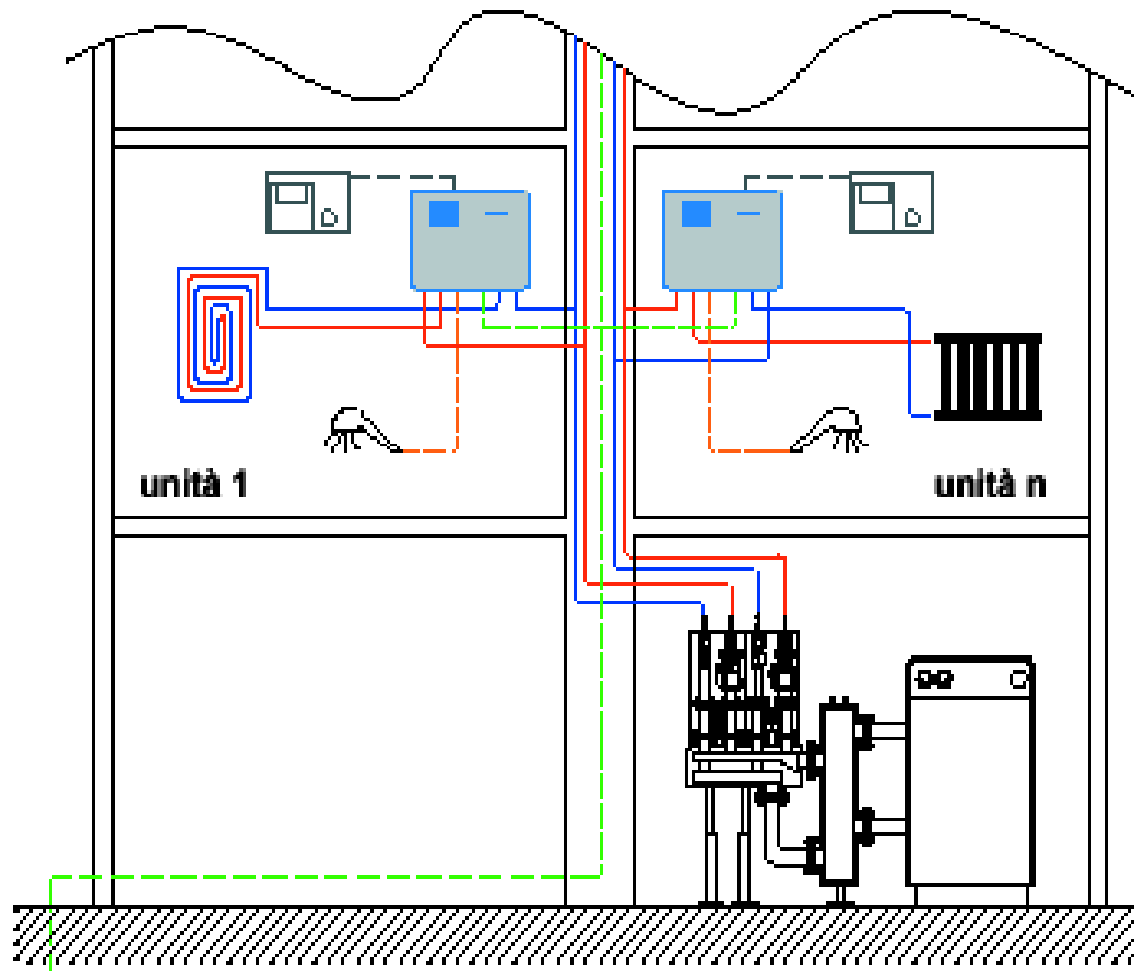

THANK YOU FOR YOUR ATTENTION